

HEAT AND CONTROL

®

MasterTherm Kettle Fryer



Heat transfer tubes and hood can be lifted clear of the fines removal conveyor to simplify cleaning.

High capacity thermal fluid heated batch fryer produces consistently uniform kettle style potato chips.

Fry 500 lbs/hr or more

Using traditional low temperature cooking, the MTKF delivers a minimum of 500 finished lbs/hr (227 kg/hr) of hard bite kettle style potato chips.

Gentle thermal fluid heating

Unique thermal fluid heat transfer tubes are immersed in the oil and deliver uniform heating with fast heat response and no burning.

Oil filtration and level control

Fines are continuously removed from the pan bottom with a wiping conveyor for superior oil quality and clean operation. Automatic oil level control maintains a consistent oil volume in the fryer.

Automatic slice stirring

Chip-Stirr® system automatically agitates slices during cooking and directs the finished chips to the discharge/drain conveyor. Chip-Stirr® prevents slice clusters, allows one operator to monitor multiple fryers, and assures consistent chip quality from batch to batch.



Chip-Stirr moves back and forth in the pan to uniformly fry potato slices.

Full PLC control

For repeatable quality in each batch, a Programmable Logic Controller automatically manages potato feed, frying, stirring, finished chip unloading, and initiation of the next batch.

Full-length hood

For safety, energy efficiency, and improved oil quality, the cooking area and Chip-Stirr are covered by a hood. This reduces heat loss and allows steam to blanket the oil, purging oxygen to prolong cooking oil quality. Exhaust volume is about 70% less than fryers using area hoods. An exhaust stack Oil Mist Eliminator removes oil droplets from exhaust emissions.

Simple cleaning

A clean-in-place spray system is built into the fryer hood. Screw jack hoists raise the hood, heat transfer tubes, and drain conveyor providing safe and complete access for cleaning.

MasterTherm Kettle Fryer

Model MTKF

Heat and Control fryers produce most of the world's potato chips! Contact us today about a batch or continuous fryer to produce your unique brand of potato chips.

Optional Equipment:

- De-oiling centrifuge
- Thermal fluid boiler
- Batching hopper for repeatable batch sizes
- Slicer feed conveyor
- Complete potato unloading, storage, preparation, seasoning, distribution, packaging and inspection systems

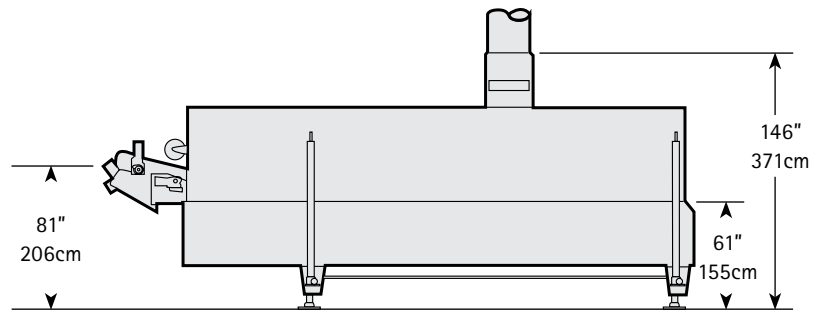
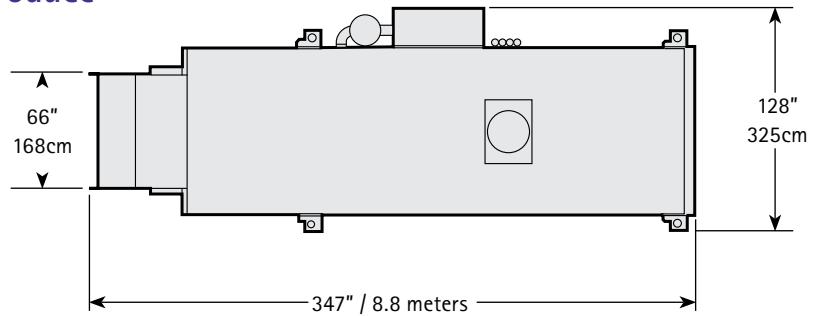

**Finished pounds/kilos per hour, depend on batch size, temperature, and potato grade. Approximate dimensions are rounded to the nearest inch/centimeter/meter or pound/kilogram.*

Potato Chip Batch Fryers for capacities as low as 150 finished lbs/hr (68 kg/hr) are also available.

Constant improvement and engineering innovations mean these specifications may change without notice.



HEAT AND CONTROL

®

